

Measuring Frequency Response

Tips & Methods

by Dr. Ray Ridley



Frequency response measurements are more crucial to the power supply industry than any other. We use a frequency response analyzer for measuring complete and partial power circuits, and each of the frequency-dependent building blocks of power circuits.

In this article, we will explain why this is so important to us, and how to obtain the maximum benefit from this essential piece of test equipment.

In our work as power supply designers, we face something unique: a wide time-constant separation encompassing events slower than 1 second, and faster than 1 ns. If you work on the bench with power supplies, you'll find yourself turning the time-base scale more frequently, and over a wider range, than any other industry due to this phenomenon.

And we expect our components to work over this range. This leads to power components being dominated not by their main value, but by their parasitic elements.

The wide separation of time constants that we see is the fundamental reason why so many of the things we do are

challenging. Simulation is ineffective in showing all the behaviors we see in power converters. EMI is pervasive everywhere, and nanosecond transitions can introduce noise and create chaotic operation in the audible range of frequency, all the way down to subsonic events.

Components are not usually characterized or specified properly by manufacturers for use in such a demanding environment. Our completed power stages are usually complex, very changeable over their range of power, voltage and temperature operation, and always noisy. Measurement is an integral part of such a world, and frequency response measurement is just as essential as time-domain measurement.

What is a Frequency Response Analyzer?

A good frequency-response analyzer is a very specialized instrument which has the following features:

- Operating frequency range from below 1 Hz to greater than 10 MHz
- Swept-sine output oscillator to drive circuit under test

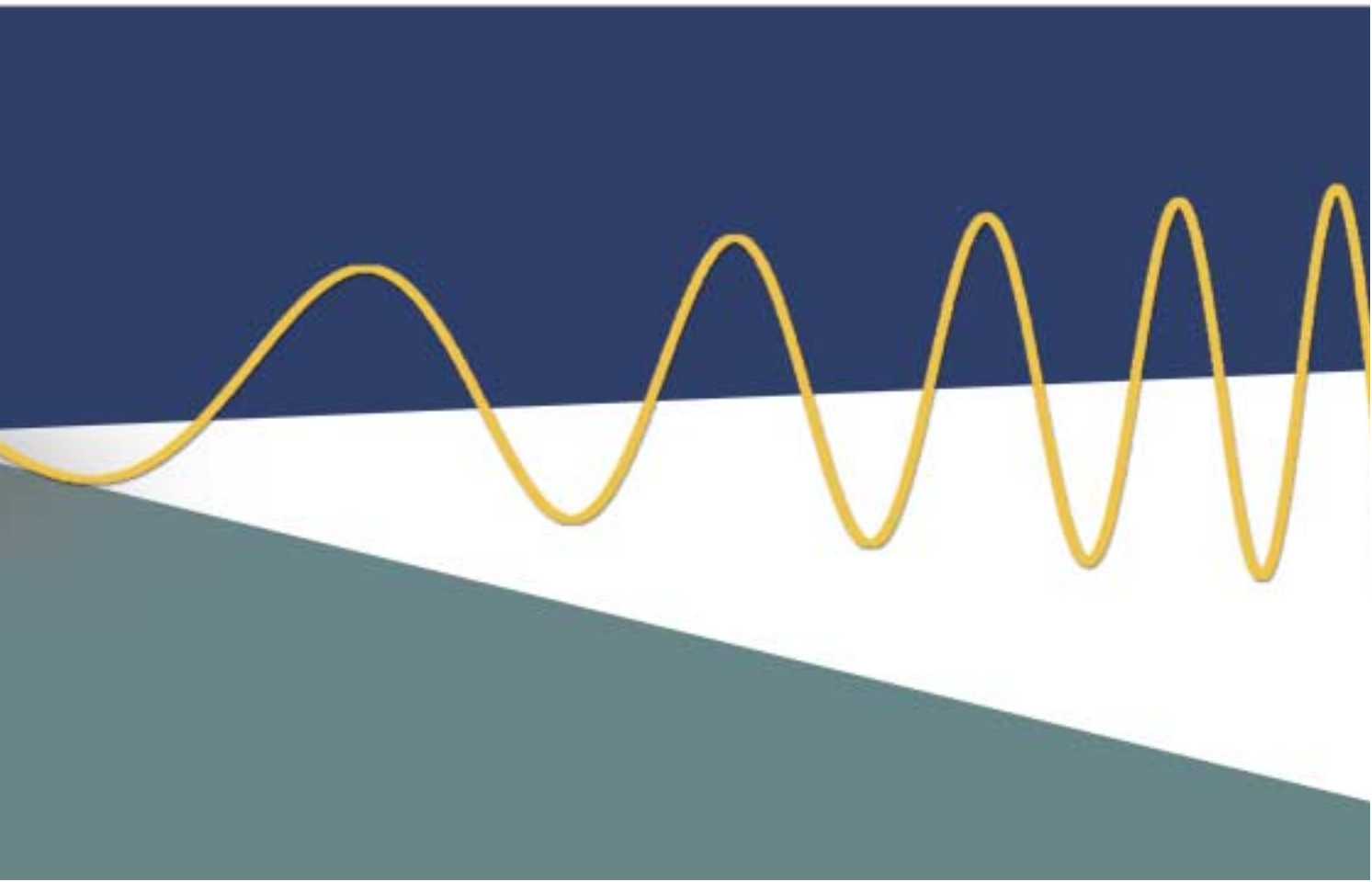

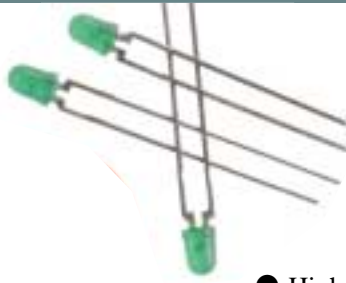

- Dual receiver channels to measure ratio of signals and phase shift of signals at the frequency of the oscillator
- High noise rejection with selectable bandwidth of the receiver channels
- Direct interface to a computer for post-processing of data

The oscillator outputs a test frequency, and the two receiver channels measure the ratio at that same frequency in the test circuit. The frequency is incremented in discrete steps from the start to the stop frequency, with a dwell time at each point to allow the circuit to stabilize.

There are no instruments that do exactly the same job. A spectrum analyzer is similar in that it can measure a test channel with a very selective bandwidth, but it does not do gain and phase comparisons.

Time-domain based equipment, such as oscilloscopes, do not have the necessary noise filters, dynamic range, tracking oscillator and measurement processing needed to perform the same function.

A signal generator in association with an oscilloscope can perform partial functions, but with very limited dynamic range of operation, and only as part of a tedious and lengthy laboratory process.

Available Equipment

The list of available frequency response analyzers grows shorter every year. The power supply industry's needs for loop measurement, and wideband, low-frequency, component characterization are unique in the world of electronics. There is not enough demand for the major equipment manufacturers to develop new products for us.

For many years, Hewlett Packard made the best piece of equipment available— the HP4194A. Capable of measuring from 10 Hz to 100 MHz in gain-phase mode, and up to 40 MHz in impedance mode, the instrument was precisely calibrated with many specialized fixtures for measuring components accurately. This instrument, priced at over \$45,000, is no longer available, although you can find them on the used equipment market for about half the original sticker price.

The Hewlett Packard HP4195 added a spectrum analyzer to the list of features available, at a higher sticker price— but this, too, is no longer available. The latest offerings from Agilent have only 50 ohm input capabilities, geared towards the much more lucrative RF test industry.

Since the early days of loop measurement, other equipment manufacturers have come and gone. The Bafco 916XH was an early all-analog instrument capable of 100 kHz operation. It even came equipped with an analog pen plotter, which is good fun for any analog engineer.

Venable Industries has been a founding presence in the industry for over 20 years, and when Dean Venable was with the company, he did a great job of spreading the word about the need to measure loop gains of power systems. Their equipment is beyond the price range of most power supply groups— around \$30,000 or more. The frequency range is also limited to only 2.2 MHz, and as we will see later, this is inadequate for capturing the characteristics of many important components that we use in power electronics.

AP Instruments is now the dominant leader in the field. Founded by Alan Phillips, who formerly worked for Hewlett Packard, they make the most practical, easy-to-use, and cost-effective analyzer on the market today. The new product, Model 200, was announced recently at the APEC 2002 conference in Dallas. Model 200 offers a notebook computer parallel interface for the analyzer, without sacrificing any features. This instrument is marketed and supported exclusively by Ridley

Engineering. We never meant to be in the business of selling network analyzers, but it was such a good product when we bought the first one for our own use in 1994 that it was a very natural product for us to carry. In addition, we needed to make sure that this type of equipment would always be available to our industry as a lab tool.

As we will see later in this article, the process of analog loop injection and measurement will be with us for decades to come. New digital control technologies will not change this fact, and we are delighted that AP Instruments will continue to develop new products to keep pace with modern technology, and provide us all with a tool that is essential to power supply design efficiency.



Figure 1: The latest new analyzer available from AP Instruments— AP200 Frequency Response Analyzer

PROGRAMMABLE DC ELECTRONIC LOADS

Specializing in Customization

- Widest Selection (60-250 KW)
- Unlimited Combinations

- "One-Box" Interface Design
- Custom Design and Modifications

60-150W

300W

600W

1.2KW

1.5KW - 4KW

60 to 250KW

KEY FEATURES

- Air-Cooled
- Pulse Programming-0.1Hz to 20KHz
- Co-existent GPIB and RS-232 Standard Interface
- 99-Points of Dynamic Power Profile Programming Capability
- Four Operating Modes (CV,CC,CR,CP)
- Power Off Memory
- Below 1.0 Volt Programming
- 256-Points of Recording and Printing Capability with Date Stamp
- Close-Case Calibration
- 256-Programmable Slew Rates Capability
- "C" Operand and Battery Testing

Note: Water-Cooled available in 6-12KW modules up to a total of 120KW



AMERICAN RELIANCE, INC.
 11801 Goldring Road - Arcadia, CA 91006 TOLL FREE: (800)654-9838
 FAX: (626)358-3838 E-MAIL: amrel@amrel.com WEBSITE: www.amrel.com

Component Impedance Measurement

Early in my career as a power supply designer, I learned the need for frequency response measurements. At my first job at Prime Computer in Massachusetts, Dean Venable visited to show the latest equipment for automated loop gain measurement. Prior to this, Dr. David Middlebrook had shown how to use manual instruments for high-noise measurements using a narrow band voltmeter in his famous analog design course.

Once we purchased a network analyzer, we quickly found that it had many uses beyond just transfer functions of completed converters. We found it an essential part of the development process to do a complete frequency response of *all* of the power components being used to build the power supply.

Once you get familiar with the use of a frequency response analyzer, you will find yourself measuring everything in sight. You'll also be surprised and disappointed in the inaccuracy of printed data from manufacturers.

Today, there is a higher level of awareness of the effects of component parasitics. We have much better components available, but the vendors are still not doing a comprehensive job in providing the full data that we need to use them. Nor should we expect them to. Their job is to make better parts for the least amount of money. No one is prepared to pay for the engineering task of measuring them properly. That has become our job as component users since we insist on performance with low cost.

Every power capacitor, inductor, and transformer that I put into a power supply is first characterized on a frequency response analyzer. It's a step that saves selecting poorly designed parts, avoids manufacturer's errors in

data, and lets me choose the most effective parts for the particular function.

Manufacturers of parts, naturally, do a good job of measuring the headline feature of a part they make. If it's a 100 μ F capacitor, it will be properly designed to measure 100 μ F plus or minus the appropriate percentage. This is the one thing on a capacitor that you actually DON'T need to measure—its capacitance.

If you have a decent frequency response analyzer, you can very easily convert it into an impedance-measuring device with sufficient range and accuracy for impedance measurements for power components.

High Impedance Measurement

There are two setups used to obtain accurate impedance measurements. One is for high impedances, and one for low impedances. The high impedance measurement setup is useful for inductors, transformers, and low-value capacitors. The basic setup for this measurement is shown in Figure 2.



Figure 2a: AP200 Frequency Response Analyzer Ready for High-Impedance Measurement

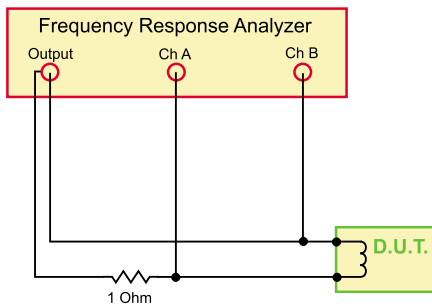

Figure 2b: Schematic of High-Impedance Measurement

This setup is a very important circuit that can be used with any frequency response analyzer, and even with a signal generator and oscilloscope (albeit with limited range). It has the important characteristic of being able to measure capacitances much lower than the input capacitance of the measurement channels, and values as low as 2 pF can be measured without any special calibration. This is very important for characterizing transformer and inductor winding capacitances and resonant frequency.

Figure 3 shows example measurements performed with this setup. These measurements are the open and short-circuit impedances of a power transformer. From this

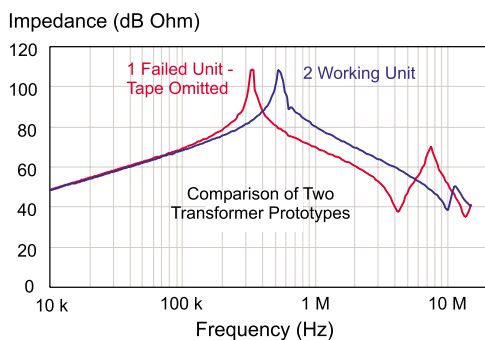
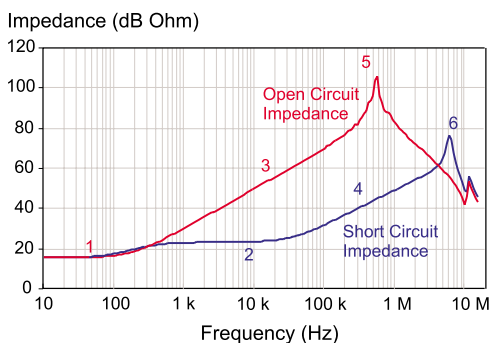

Figure 3: Example Transformer Measurements

data, you can extract magnetizing inductance, leakage inductance, winding capacitance, resonant frequency, and Q. The second plot shows how a single layer of insulating tape omitted from a sample transformer led to a significant shift of the frequency response, and failure in the power supply.



In power supply design, collecting this data across the full range from 10 Hz to 15 MHz is an important part of the design documentation. It provides a complete picture of component performance over the full frequency range of operation, and a good basis for comparison of alternate source parts, and magnetics provided by manufacturers during the progress of your project. Simple RLC numbers at a single frequency are much less revealing of potential changes and compromises in design.

This setup works well for impedance greater than the value of the sense resistor of Figure 2b. The range can be shifted up or down by changing the sense resistor, but for low impedances, it is preferable to switch to a low-impedance setup with proper Kelvin connections.

Low Impedance Measurement

The low-impedance measurement setup is shown in Figure 4. This setup cannot resolve high impedances, but can measure impedances as low as 1-mOhm up to above 100 kHz. The setup requires a wideband isolation transformer, and a Kelvin connection to the device under test. This is useful for large value, low-ESR capacitors commonly used in power supplies.



Figure 4a: AP200 Frequency Response Analyzer Ready for Low-Impedance Measurement

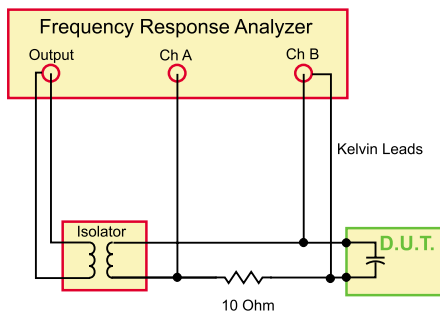

Figure 4b: Schematic of Low-Impedance Measurement Circuit

Figure 5 shows example measurements performed with this setup. These measurements are of several different capacitors, including multilayer ceramic electrolytic, and tantalum. The extremely low ESR of the multilayer ceramic can be clearly seen, and the effective range of each capacitor is shown. This impedance characteriza-

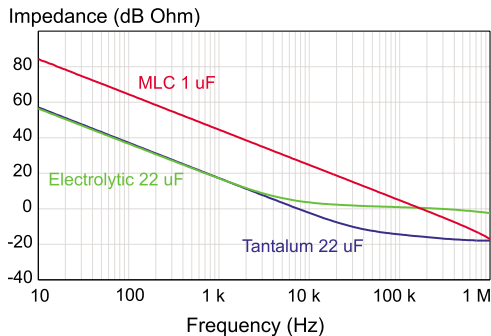

Figure 5: Example of Electrolytic, Tantalum, and Multilayer Ceramic Capacitor Impedances

tion step lets you optimize the addition of the right type and number of capacitors.

Being able to accurately extract the ESR for the capacitors you are using is very important during product development. We have learned over the years that manufacturers specify ESR very loosely. It is often specified much higher than it measures. While this gives a better power performance than the data sheet promises, it is a big problem when you are relying on the ESR for loop compensation, or filter

damping, as is often the case in power supply design. We will see an example of this in the loop gain section of this article.

Figure 6 shows the total dynamic range of impedance measurements using the Model 200 Analyzer. This requires only two different sense resistor setups, and is usually sufficient to cover the range of all the power components that you will encounter in your design. The range can be extended further in special cases by changing the sense resistor values.

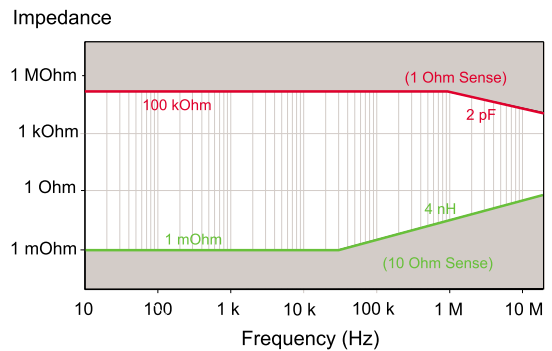

Figure 6: Dynamic Range of Impedance Measurements with the AP Model 200

Transfer Function and Loop Gain Measurement

The most widely known use of a frequency response analyzer is for loop gain measurement. This is the most challenging application for the instrument, and some care must be applied in making these measurements. A typical power supply loop gain will push the frequency response analyzer's specifications of dynamic range and noise rejection to the limit.

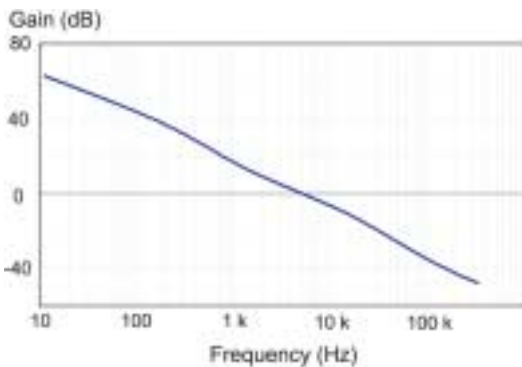

Figure 7: Typical loop gain showing high gain at low frequency, and 5 kHz crossover frequency.

First, we'll explain the difficulties involved in making these measurements. Figure 7 shows a typical power supply loop gain measured with a frequency response analyzer. At the low frequency end of a power supply loop measurement, the gain of the system will be very high— in excess of 60 dB, and sometimes as high as 80 dB. Consider the size of the signals needed to make this measurement. You must ensure that you are measuring “small-signal” with a small AC perturbation on top of the DC operating point. For this, the injected perturbation signal riding on the output will typically be 100 mV or less.

The input signal to the loop, for a 100 mV output, will be 0.1 mV for a gain of 60 dB, and 10 μ V for a gain of 80 dB. It is common, however, to have several hundred mV of noise in the signals, as shown in Figure 8. It is impossible to measure the test signal in so much noise without a specialized instrument. This is where a true frequency response analyzer provides its value— extracting the test frequency

only, with a very narrow bandwidth, so system noise does not interfere with the measurements.

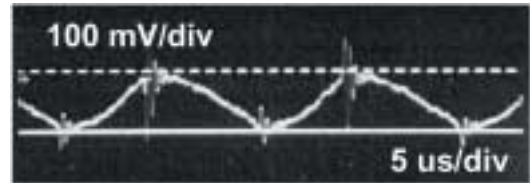

Figure 8: Typical test signal to be measured, with switching spikes and other noise. Less than 0.1 mV test signal must be accurately measured in the presence of over 200 mV noise.

Ultimate Transformer and Inductor Databook 2002

DATABOOK
TRANSFORMERS & INDUCTORS
INCLUDING FACILITIES AND CAPABILITIES

New 185+ page Databook with thousands of switch mode magnetics to choose from. To get your copy visit our website at www.rencousa.com and click 'catalog' or simply call toll free 1-800-645-5828.

RENCO ELECTRONICS, INC.
SINCE 1955

Renco Electronics, Inc.
595 International Place
Rockledge, FL 32955-4200 USA
Phone: 321-637-1000
Fax: 321-637-1600
Web Site: www.rencousa.com
E-mail: sales@rencousa.com

With the AP200 Frequency Response Analyzer

NEW parallel port compatibility! Designed specifically for switching power supplies, the AP200 is an essential development tool to ensure stability and design integrity. The Analyzer makes swept frequency response measurements that give magnitude and phase data plotted versus frequency.

Measurement

An example of a power supply loop gain measurement using the AP200 Frequency Response Analyzer:

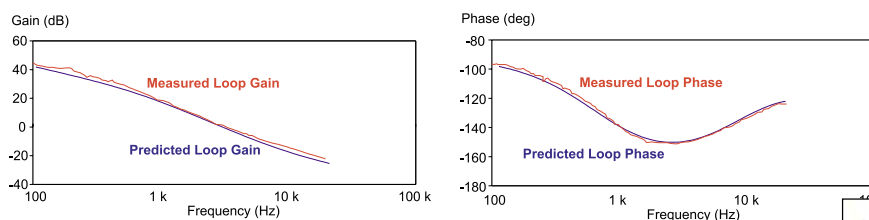

Pricing & Services

Analyzer & Accessories:

Analog source/receiver unit AP200 Parallel <i>includes Digital Signal Processing (DSP) unit, Interface cables, and software</i>	\$12500
Differential Isolation Probes	\$650/pair
5 Hz to 15 MHz Injection Isolator	\$395
Overseas Orders	add \$600
Power 4-5-6	\$795*
*discounted price available only when purchasing the AP200	



Services:

Rental Units	\$1400/month
Consulting	\$250/hr + travel expense for On-Site \$200/hr Off-Site

Loop Gain Test Setup

Power supplies are extremely high DC-gain systems. They use integrators to maximize the DC gain, and ensure that the output voltage DC regulation is tight. The power supply and control circuits cannot, therefore, be run with the loop open. It's simply not possible to hold the DC operating point steady with an open loop system.

Fortunately, there are established and documented techniques for measuring the open loop gain of a system while the loop is kept physically closed. The only invasion into the circuit is through the insertion of a test resistor. The technique is very accurate as it does indeed measure the true open loop gain of the system, not a gain modified by the injection technique itself.



Figure 9a: Frequency Response Analyzer Ready to Measure Loop Gain of a Power Supply

This is shown in Figure 9. The only complication with this technique is that the signal injected into the circuit must be injected *differentially* across the resistor, not with respect to ground. The output signal from the network analyzer is coupled through an isolation transformer. This is preferable to an active device that may interact with the circuit.

It's a little unusual how this works—the signal size *across* the resistor is constant, determined by the output source of the analyzer. The vector sum of the injected signal and return signal are exactly equal to this injected signal. The power supply feedback system will adjust the signal sizes according to the gain of the loop. For example, if the gain of the system is 60 dB, and the injected signal is 100 mV, almost the entire injected signal appears across the output and only 0.1 mV across the input.

At the crossover frequency, the injected signal is distributed equally between input and output signals. And, when the gain of the system is very low, beyond the crossover frequency, most of the signal is applied to the loop input, and only a small fraction to the loop output. Signal distribution at different frequencies are shown in Figure 10.

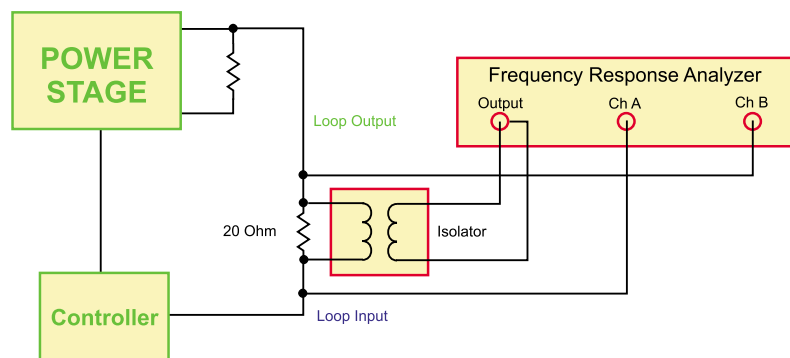
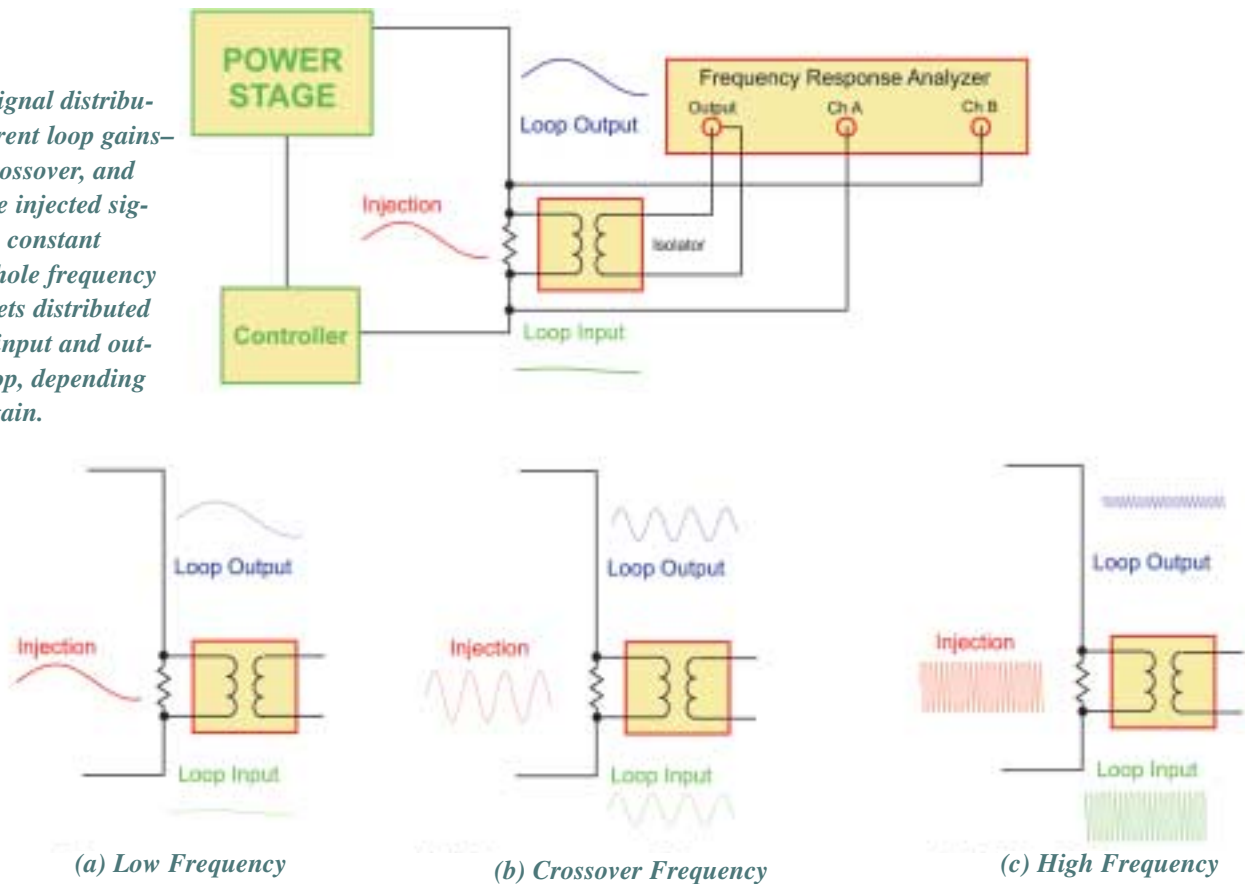

Figure 9b: Feedback loop system showing frequency response analyzer connection and injection resistor.

Figure 10: Signal distributions at different loop gains—high gain, crossover, and low gain. The injected signal size stays constant across the whole frequency range, and gets distributed between the input and output of the loop, depending on the loop gain.



Inductors **EMI/RFI** **Transformers**

You'll find what you need here...

www.delevan.com

Visit our website for:

- World-wide Support Network
- Engineering, Sales, & Customer Service Contacts
- On-Line Sample Requests
- Your Total Magnetics Source

API Delevan

716-652-3600 • Fax: 716-652-4814 • email: apisales@delevan.com

An animated example of this process can be seen at the Ridley Engineering web site, www.ridleyengineering.com showing graphically how the injected signal is divided between loop input and output.

In order not to disturb the operating point of the system, the injection resistor is kept small relative to other components in the circuit. Typically, a 20 or 50 ohm resistor is used.

During measurement, it is usually advisable to monitor critical waveforms of the control system to make sure that they remain in the small-signal region. An oscilloscope probe on the output of the error amplifier, and output of the power supply, is usually sufficient. As the gain of the loop changes, it is customary to adjust the size of the signal injection to keep the signals large enough to be measured, but small enough keep the system linear.

When you first make loop measurements, you may become frustrated with the noise level at low frequencies compared to the textbook loop measurements that you may see in papers. It takes a great deal of time to collect data and smooth out all of the noise, with many averaged sweeps.

Example Loop Measurement

A printer power supply company was ready to release a design to manufacturing. A substantial amount of modeling and prediction ensured system stability. The power supply was considered ready for production with quantities exceeding 100,000 units per month.

The company had a frequency response analyzer in house, ready for evaluation. But, like many of us, the engineer was too wrapped up in the production details to take loop gain measurements.

Finally, he was persuaded to do a quick test with the analyzer on this latest product. Reluctantly, he did, taking a couple of hours out of his schedule.

To his amazement, the power supply was almost unstable, with only 35 degrees of phase margin at the selected nominal operating point— 50 degrees lower than expected. The production release was delayed for a day to correct the problem.

The model the engineer was using was fine, and all the values corresponded to the manufacturer's data for the passive components. And that's where the problem lay—the wrong value of ESR for the output capacitor was being used. It was correct according to the data sheets, which called

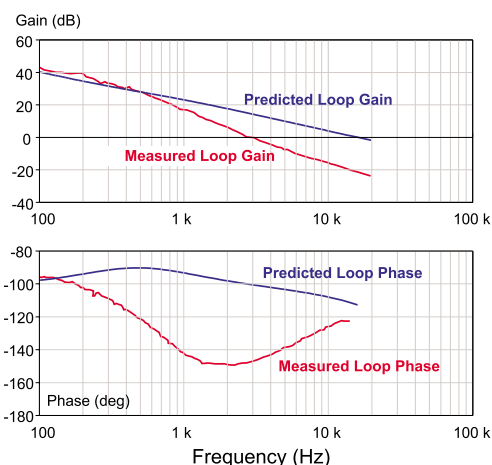

Figure 11a: Predicted and measured power supply loop gains using manufacturer's data for capacitor ESR. Over 50 degrees phase error!

out a *maximum* value of 7.5 ohms for a tantalum capacitor. The *real* value of the ESR was only 0.25 ohms, which is a factor of 30 lower than the published maximum! This corresponded to a change in gain of 30 dB at higher frequency. And, since we often cross a control loop over in the region where the output capacitors are resistive, the whole loop gain was depending on this value.

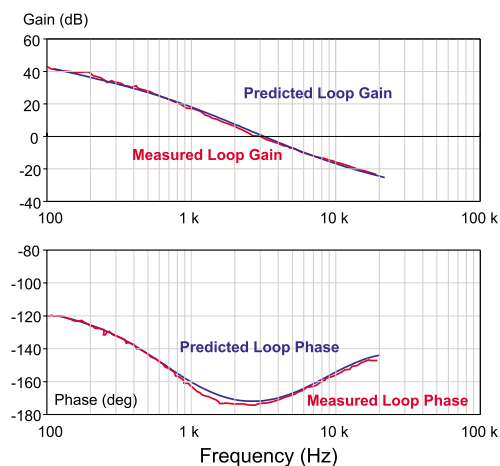

Figure 11b: Same measured loop gain as Fig. 11a, but predicted loop gain using measured values of capacitor ESR (30 times lower).

A refinement to the model values confirmed the measured loop gain, and the need to add a couple of additional compensation components to the board. Cost to the program was only a few hours engineering time, and the changes were incorporated in the final production board run the next day. The savings in potential product recall and re-engineering were substantial.

This example is more the norm than the exception. We are surprised when measuring the loop. That's one of the key reasons that this step remains a critical part of our industry.

Other Transfer Function Measurements

There are many more quantities that can be measured in a power supply. Input impedance, output impedance, and audiosusceptibility are all important measures of system performance. The question is often asked of us— can you measure this?

The answer is usually the same: We can measure anything, if you can perturb it enough to give us something to measure. And that is not always an easy task, frequently requiring custom test circuits to inject into your power stage.

For example, we were recently asked if we could

measure the impedance of the input connections to a power supply. The problem was that the input bus was at 300 V, and there was 700 A flowing into the power

supply. Yes, it can be measured. Putting a signal into the system in order to make the measurement is much more difficult.

There is no standard, off-the-shelf equipment for doing this type of function. Over the years, engineers have created their own perturbation circuits, and we have some favorites of our own. Figure 12 shows a few simple test circuits that can be used for measuring output impedance at different power levels. Figure 13 shows a test circuit for injecting a test signal into the input bus of a power supply in order to make either input impedance or audiosusceptibility (input-to-output transfer function) measurements. This test is the most invasive of all the frequency response measurements since you must cut into the main power bus.

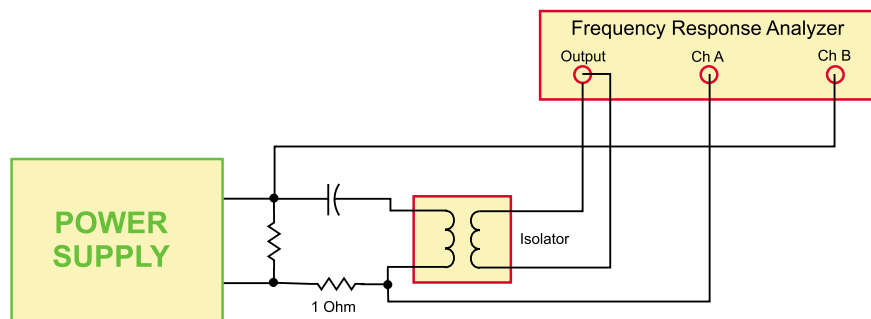

Fig 12a: Low-Power Output Impedance Measurement (<100 W)

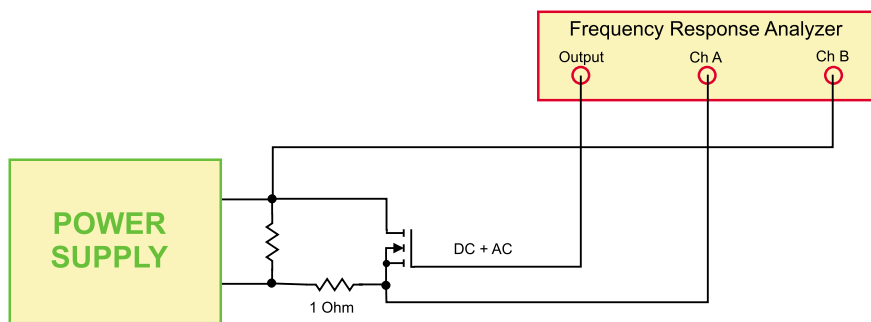
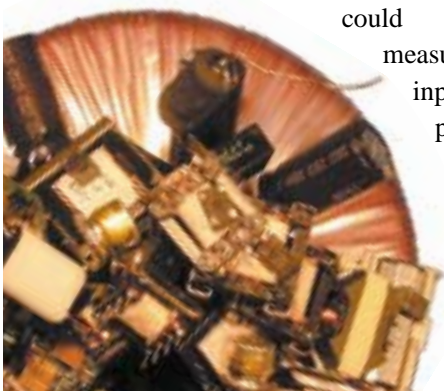

Fig 12b: High-Power Output Impedance Measurement (>100 W)

This test brings up the problem of how to interface the measurement channels to high-power and high-voltage circuits.

All frequency response analyzers have limitations of voltage that can be applied to their input terminals, and care must be taken to protect them. In the early days of measurements, Dr. Middlebrook taught us the neat trick



of buffering the signals with an oscilloscope if they were too high or not ground referenced, but it is becoming harder to find scopes that still provide the analog output signal. Fortunately, battery-powered differential isolation probes are readily available to solve this problem. These provide complete isolation for the input channels up to 1000 VAC, both common and differential mode. The probes are used extensively by instrument makers, and can measure accurately to 20 MHz.

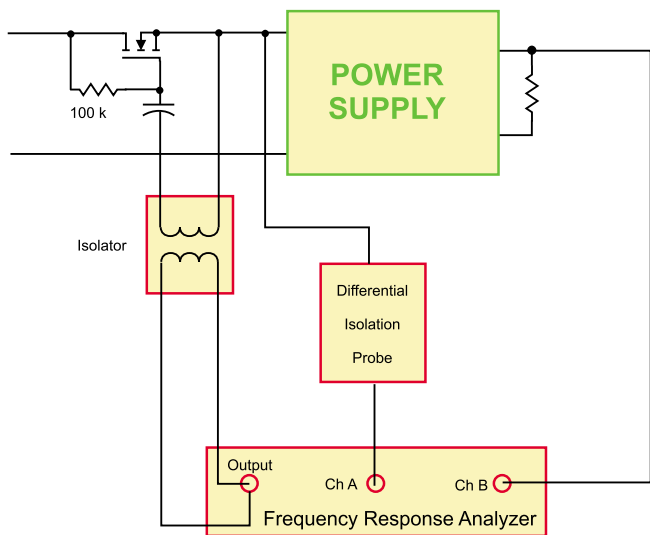

Fig 13: Input Injection for Audiosusceptibility and Input Impedance Measurements

The Future: Digitally Controlled Power Systems

As we mentioned in the last issue of *SPM*, it is no longer a question of whether digital controllers will dominate the world of power supplies, but when. This view was reinforced by the recent APEC 2002 conference where several companies and university researchers presented viable controllers serving all the functions of the PWM controller, including the pulse-width modulator itself.

This gives rise to the following questions: Will we need to continue to make analog loop gain measurements in the future? Why can't the embedded processor measure its' own loop? These are good questions, and there are several important reasons why analog loop measurement will remain a part of our industry for many years to come.

Firstly, it takes far too much circuitry and processing power to inject, filter, process, and measure the equivalent of an analog loop with an imbedded processor. The microprocessor would have to fill the entire function of the frequency response analyzer to do this. That simply doesn't make sense. The hardware and software needed would burden the cost of the power system.

So why can't the processor measure the system, and work strictly in the digital control, or z-domain? The main reason for this goes back to the starting topic of this article—the very large separation of time constants in a switching power supply. The new digital processors can sample the power supply states very rapidly, but we still have a low pass filter in the power system—the fundamental building block of the PWM converter. Some of the states can be moved rapidly from one cycle to the next, such as controller states and inductor current, for example. But other filter states, such as the output capacitor, barely move from one cycle to the next, even under maximum drive.

This leads to discrete time poles of the system that cluster just inside the +1 point of the unit circle. It is extremely difficult to design such a system in the discrete time domain, and it is also numerically unstable to attempt to measure the poles with sufficient accuracy to predict the slow-moving transients of the power systems.

This effect has long been known. Computer-controlled systems have been with us for decades in other industries. Chemical processes, and other industrial processes are frequently controlled by microprocessors, but the slow-moving process is measured and compensated with analog means.

In summary, measurement of control loops and components with a frequency response analyzer is an integral part of developing power supplies. Learning the techniques and skills in this article will help you design your power systems faster and better. And frequency response analyzers are now affordable, easy-to-use, and very powerful.